

AIRMATE

SUBMITTAL DRAWING

- HEAVY GAUGE STEEL CONSTRUCTION FOR FLOOR USE
- MULTI-ANGLED FIN SETTING
- FOOT-OPERATED, OPPOSED BLADE DAMPER
- FINISH: WHITE (W) OR BROWN (BR) ENAMEL
- MEETS LOAD TEST REQUIREMENTS OF THE INTERNATIONAL MECHANICAL CODE SECTION 603.18.1 AND H.U.D. 3280.715(e)(2)

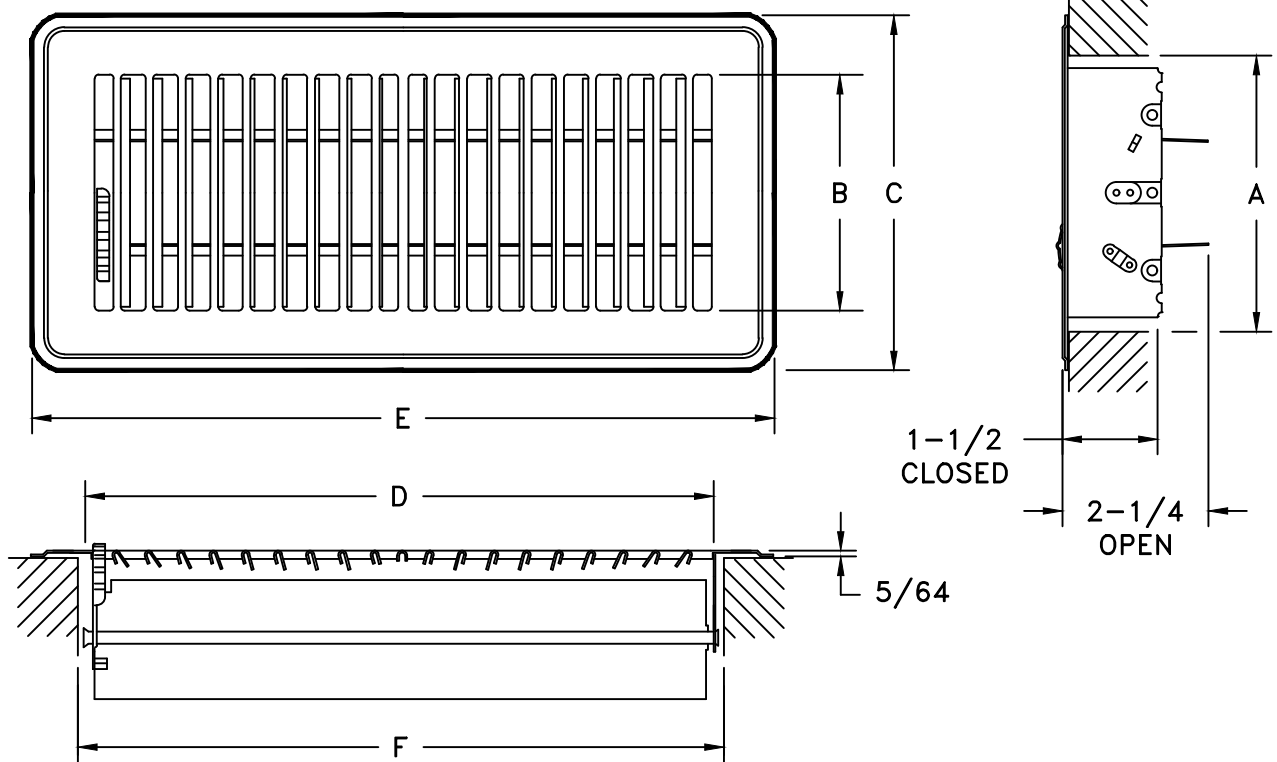

SIZE A X F	FREE AREA SQ.IN.	DIMENSIONS (SEE DETAIL SKETCHES)			
		DAYLIGHT OPENING		OVERALL	
		B	D	C	E
2 X 10	15	2	9-5/8	3-3/4	11-1/2
2 X 12	17	2	11-5/8	3-3/4	13-1/2
2 X 14	20	2	13-5/8	3-3/4	15-1/2
4 X 8	22	3-3/4	7-5/8	5-1/2	9-1/2
4 X 10	27	3-3/4	9-5/8	5-1/2	11-1/2
4 X 12	32	3-3/4	11-5/8	5-1/2	13-1/2
4 X 14	37	3-3/4	13-5/8	5-1/2	15-1/2
6 X 10	39	5-1/2	9-5/8	7-1/2	11-1/2
6 X 12	48	5-1/2	11-5/8	7-1/2	13-1/2
6 X 14	56	5-1/2	13-5/8	7-1/2	15-1/2

JOB NAME: _____	SUBMITTED BY: _____	DATE: 09/17/2021
LOCATION: _____		302A Steel Floor Diffuser
ARCHITECT: _____		
ENGINEER: _____		
CONTRACTOR: _____		