

- ALUMINUM STEEL CONSTRUCTED CURVED BLADE REGISTER FOR CEILING OR SIDEWALL
- STEEL MULTI-LOUVERED DAMPER
- ALUMINUM MITERED CORNER FACE WITH 1"–RADIUS ALUMINUM CURVED BLADES AT 3/4" SPACING
- FINISH: WHITE (CW) ENAMEL

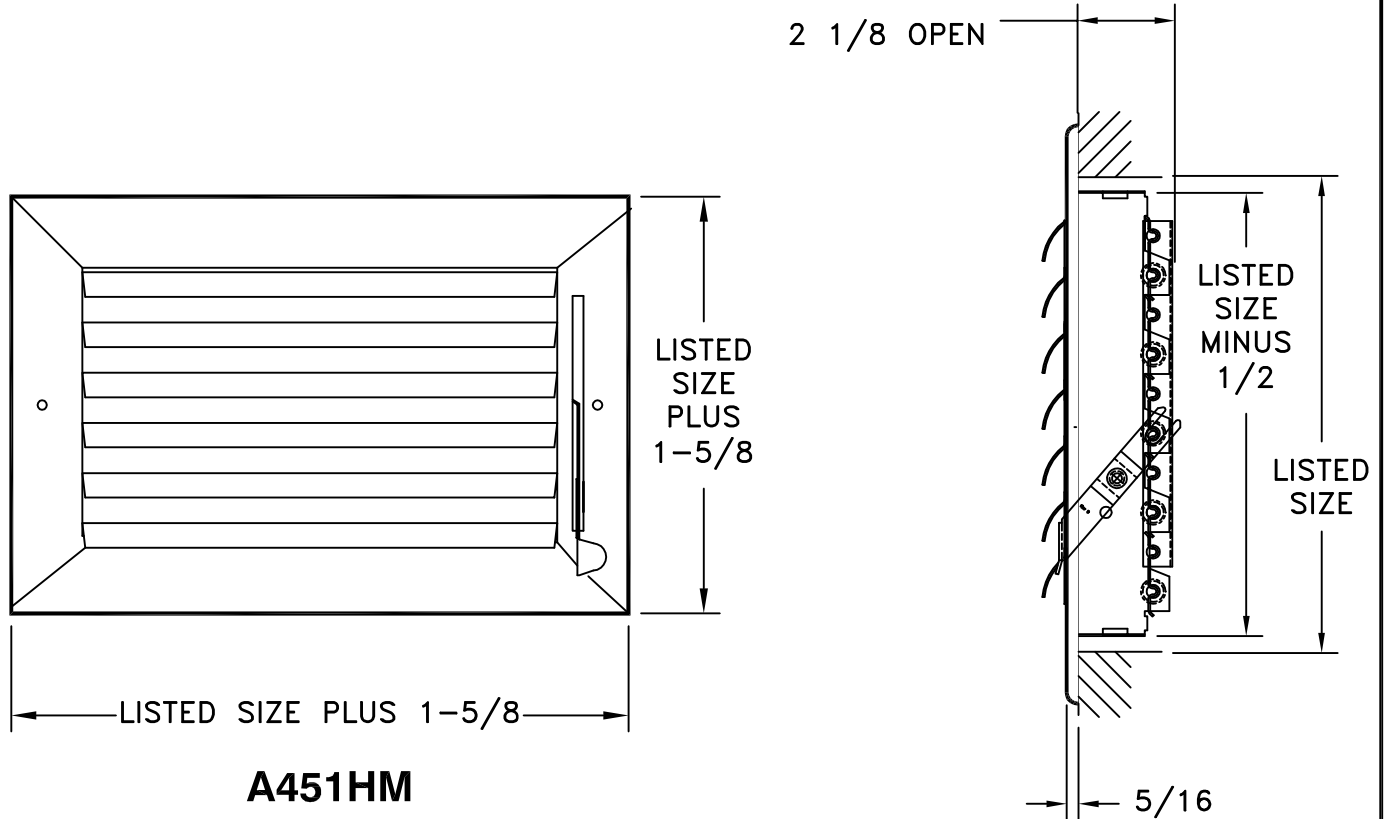

A451HM

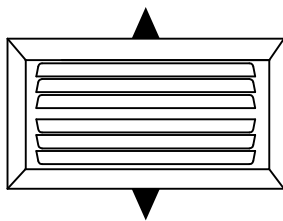

A452HM

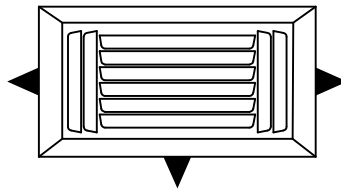

A453M

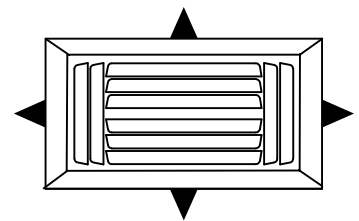

A454M

DAMPER AND DIMENSIONS ARE TYPICAL FOR ALL DEFLECTIONS

JOB NAME: _____	SUBMITTED BY: _____	DATE: 07/20/2014	AM-A450
LOCATION: _____		A450 SERIES	
ARCHITECT: _____		Adjustable Curved Blade	
ENGINEER: _____		Register	
CONTRACTOR: _____			