

- STEEL FACE AND DAMPER CONSTRUCTION, BLADES ARE ALUMINUM.
- SCREW DRIVER OPERATED OPPOSED BLADE DAMPER
- INDIVIDUALLY ADJUSTABLE BLADES, 13/16" FIN SPACING
- FINISH: BRIGHT WHITE OR PAINTED ALUMINUM

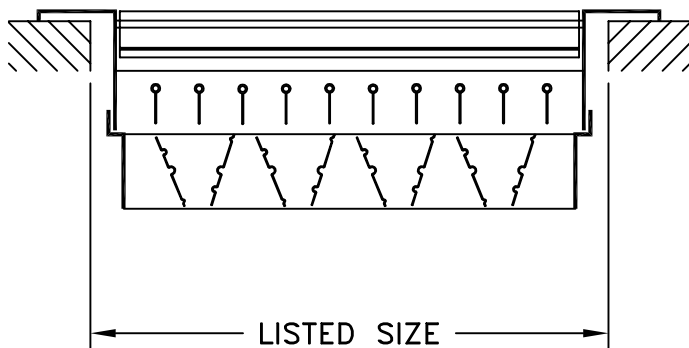
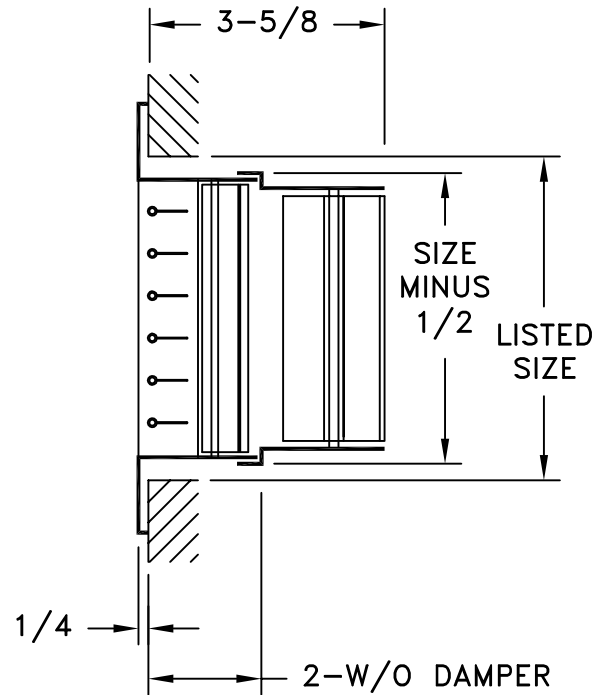
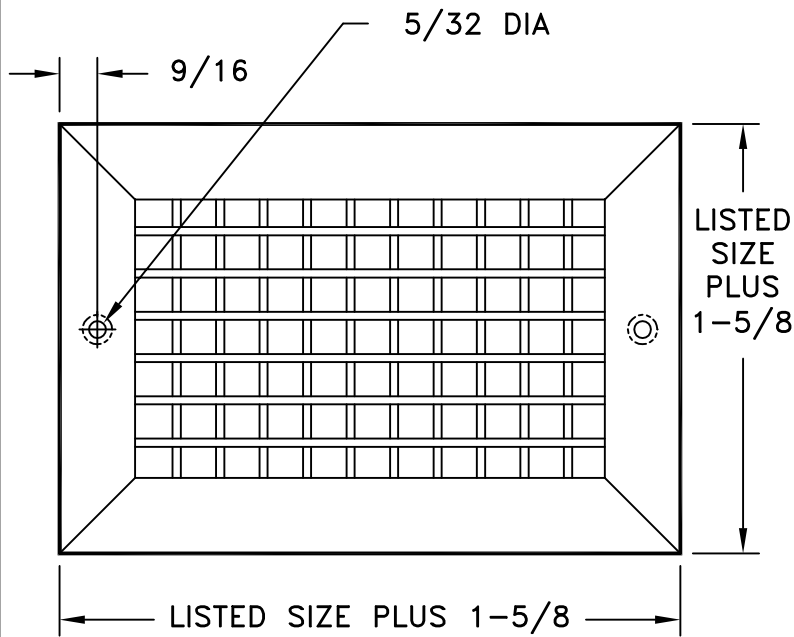

MODELS AVAILABLE

- 240V/240VO
- 240H/240HO

JOB NAME: _____
 LOCATION: _____
 ARCHITECT: _____
 ENGINEER: _____
 CONTRACTOR: _____

SUBMITTED BY: _____

DATE: 08/12/2014 | AM-240V/240H
240 SERIES
 Double Deflection Register With
 Optional Opposed Blade Damper