

- EXTRUDED ALUMINUM CONSTRUCTION. DOUBLE DEFLECTION.
- OPTIONAL SCREW DRIVER OPERATED STEEL OPPOSED BLADE DAMPER
- INDIVIDUALLY ADJUSTABLE BLADES, 2/3" FIN SPACING
- FINISH: BRIGHT WHITE OR PAINTED ALUMINUM

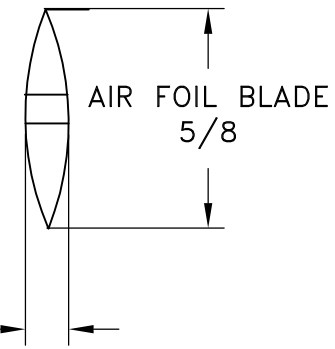
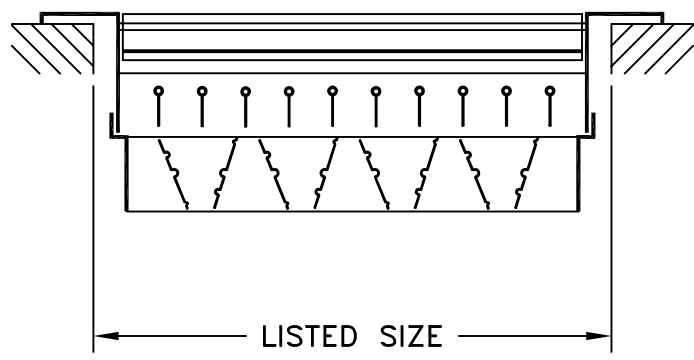
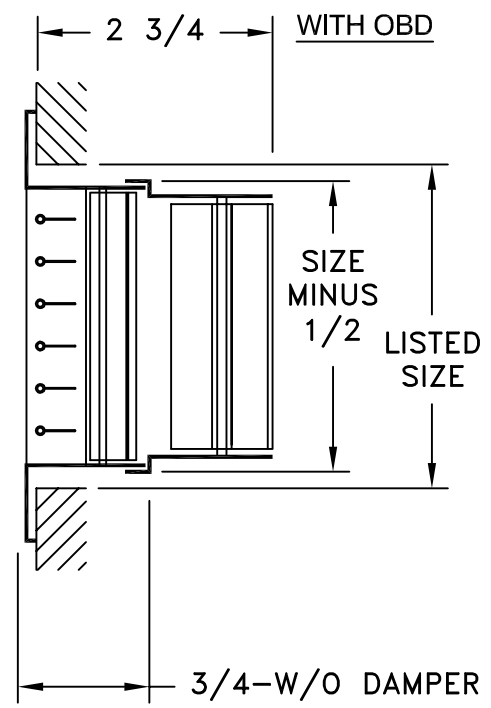
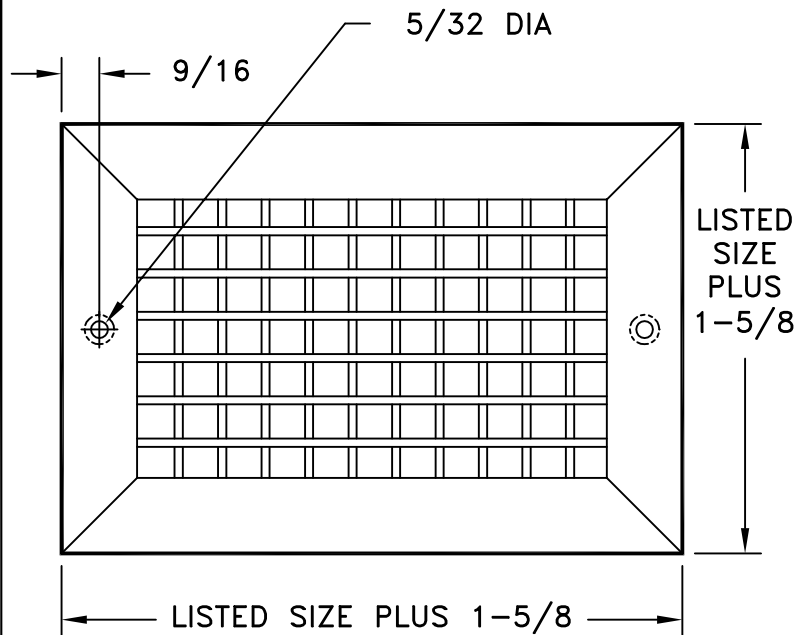

MODELS AVAILABLE

- E240V/E240VO-VERTICAL FRONT BLADES
- E240H/E240HO-HORIZONTAL FRONT BLADES

JOB NAME: _____

LOCATION: _____

ARCHITECT: _____

ENGINEER: _____

CONTRACTOR: _____

SUBMITTED BY: _____

DATE: 08/12/2014 | AM-E240V/E240H

E240 SERIES
 Extruded Aluminum Double
 Deflection With Air Foil Blades
 Optional Opposed Blade Damper