

- EXTRUDED ALUMINUM CONSTRUCTION
- MODULAR CORES PROVIDE FOUR-WAY, THREE-WAY, TWO-WAY, OR ONE-WAY HORIZONTAL AIR PATTERNS
- REMOVABLE MODULES PROVIDE EASY ACCESS TO ACCESSORIES
- BEVELED MARGINS ARE DESIGNED TO COVER THE CEILING OPENING AND MINIMIZE SMUDGING
- ALUMINUM OPPOSED BLADE DAMPER AVAILABLE, SPECIFY AS E464B-0
- MINIMUM SIZE: 6 X 6
- MAXIMUM SIZE: 22 X 22
- AVAILABLE IN 2 INCH INCREMENTS, SQUARE SIZES ONLY
- FINISH: WHITE (W) ENAMEL AND SATIN ANODIZED (SA)

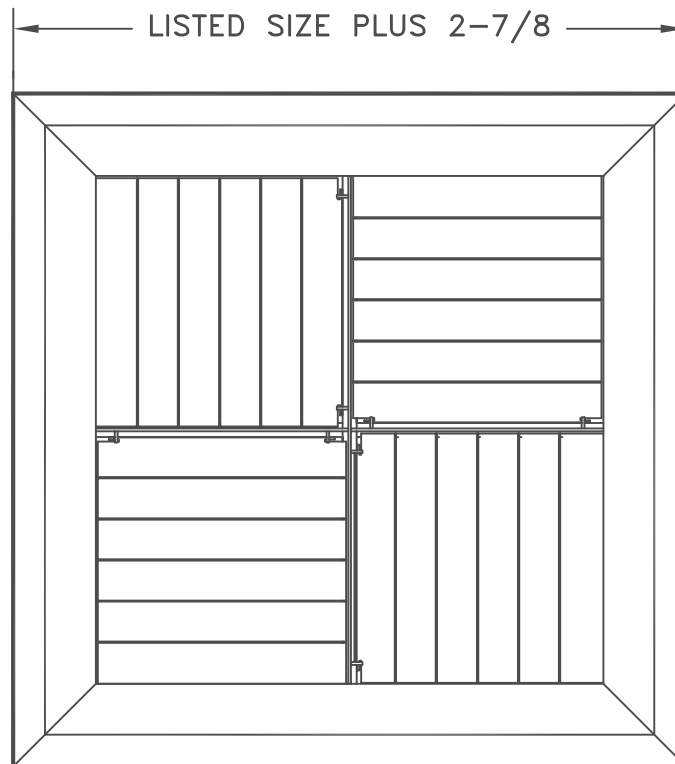
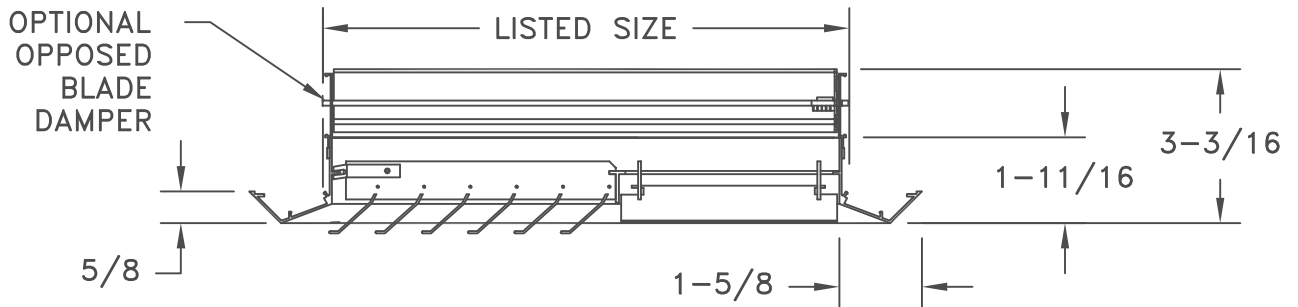

JOB NAME: _____	SUBMITTED BY: _____	DATE: 4/26/11	AM-E464B, E464B-0
LOCATION: _____		E464B, E464B-0 Modular Ceiling Diffuser Step Down Margin	
ARCHITECT: _____			
ENGINEER: _____			
CONTRACTOR: _____			